

These instructions are written by two users on RCGroups: jj604 and Daedalus66. We have no connection with Lemon RX.

LemonRX and OrangeRX are brand names. Spektrum, DSM2, DSMX, X-BUS, Airware, STi, and the Telemetry logo are Trade Marks of Horizon Hobby. These names are used here simply as descriptions of those items.

NOTE: Any DSM2 and DSMX logos have been obliterated in the photographs to avoid any Trademark issues.

Instructions for Lemon RX Receivers

1. The Distinction between DSM2 and DSMX	1
2. Binding.....	2
3. What the LEDs Mean.....	3
4. Antennas and Satellites	4
5. Connections and Switches on the Various Lemon Receivers.....	6
6 channel DSM2-compatible.....	6
6 channel DSM2-compatible Ultra-Light.....	7
6 channel DSM2-compatible Micro Light.....	7
6 channel DSMX-compatible	8
7 channel DSMX-compatible stabilizer	8
8 and 10 channel receivers	9
8 channel DSMX-compatible PPM receiver.....	10
Satellite Receivers.....	10
6. Failsafe	11

1. The Distinction between DSM2 and DSMX

Lemon RX makes both DSM2-compatible and DSMX-compatible receivers, though increasingly their range of products emphasizes DSMX compatibility. The DSMX protocol developed by Spektrum includes frequency hopping for more reliable operation in areas of high potential interference from other 2.4GHz transmitters, but receivers using the older DSM2 protocol, also by Spektrum, continue to work well in all but the most demanding conditions.

Lemon “**DSMX-compatible**” receivers work with any DSMX-compatible transmitter and are backward compatible with older DSM2-type transmitters.

Lemon “**DSM2 compatible**” receivers work with either a DSM2-compatible transmitter or a DSMX-compatible transmitter operating on DSM2. Most recent Spektrum DSMX transmitters support both modes and will automatically detect a DSM2 receiver at bind time (*No longer true in the EU – see below*).

EU Update. *A significant change of regulations in the European Union requires that transmitters sold there after January 1, 2015 NOT include DSM2 modulation. Consequently, new DSMX transmitters now sold in the EU support only DSMX-type receivers. Transmitters sold previously that include DSM2 capability will continue to be fully legal for use.*

DXe Update. *The EU requirements do not directly affect other parts of the world, but the new (2015) low-cost Spektrum DXe transmitter supports only DSMX, wherever it is sold in the world. Other Spektrum transmitters, including new ones released in early 2016, continue to support both DSMX and DSM2 except in the EU.*

2. Binding

Binding is the process of “locking” the receiver to its own transmitter (and, where relevant, to a particular model memory within the transmitter) so that it ignores any others. Binding is the first step in setting up any receiver. Ensure the transmitter and receiver are separated by 3-6ft/1-2m or the transmitter may “swamp” the receiver. Occasionally, it may be necessary to have as much as 10ft/3m separation to achieve binding. Generally you should only need to bind once and, after binding, normal link-up should not require more than a couple of feet of separation.

Step 1. Power up the receiver in bind mode

For most receivers: put the bind plug on to the bind pins. For 6-channel Ultra Light and Micro Light receivers, press and hold in the bind button.

Connect a suitable power source to the receiver throttle servo pins. This can be:

- a receiver pack battery (generally 3.45 – 7.2v)¹; or
- a stand-alone BEC; or
- the throttle connection from your speed controller (ESC) with inbuilt BEC (if the ESC is in a model, disconnect the motor or remove the propeller).

The red LED on the receiver will flash rapidly to indicate bind mode. If it doesn't, you have a problem (such as reversed power connector). Make absolutely sure the LED is flashing rapidly before going any further.

Step 2. Turn on transmitter in bind mode

On some transmitters bind mode is activated by holding the Trainer button/switch or bind button while powering up. Others require going into a menu to enable bind mode. If in doubt, read the manual.

Where appropriate, continue to hold the switch/button until the receiver LED stops its rapid flashing. Release it at that point and the bind process will complete. A solid light on the LED indicates successful bind.

Some transmitters will display on screen or announce the type of bind (DSM2 or DSMX) and the frame rate (normally 22mS).

Step 3. Power down and test

Remove power from the receiver, **remove the bind plug** (very important!) and switch the transmitter off.

Turn the transmitter back on, then apply power to the receiver to check that the receiver operates properly and servos respond to the transmitter controls.

¹ Check individual specifications as some receivers may work within a different voltage range.

NOTES:

1. If a satellite is used, it must match the main receiver; that is, a DSM2-compatible receiver should have a DSM2-compatible satellite, and likewise for DSMX-compatible units.
2. If your receiver uses a satellite then binding **MUST** be done with the satellite connected. Both receiver and satellite LEDs should flash rapidly at the beginning of the bind process, then become solid.
3. Binding can be done with or without servos. Servos plugged in the wrong way round may prevent binding, so check this if you have difficulty.
4. If you experience difficulty getting a DSM2-only receiver to bind with a DSMX transmitter, try forcing the transmitter into DSM2 mode (if the option is available).
5. Always perform a range check after binding, using the range check function on your transmitter. This attenuates transmitter power so that range is reduced by a factor of about 30. With Spektrum transmitters, full control in range-check mode at 30 yds./25m (roughly 30 paces for many adults) indicates ample range for normal visual flying. It is good practice to perform a range check at the beginning of every day's flying to ensure everything is working properly.

3. What the LEDs Mean

All Lemon receivers and satellites have a red LED. Some, including the 7-channel stabilizer, also have LEDs of other colors.

1. A **rapidly flashing red LED** indicates the receiver is in Bind mode
2. A **solid red LED** indicates normal radio link between receiver and transmitter.
3. **No red LED** means there is no radio link.
4. A **slowly flashing red LED on a receiver in DSM2 compatible mode** indicates that there has at some stage since it was powered up been a power loss or significant voltage drop (however brief), often called a "brownout". The flashing may indicate an inadequate receiver power supply or it may mean simply that the operator failed to turn off the transmitter when powering down the receiver. It does not indicate a range or signal loss issue. Receivers in DSMX-compatible mode do not provide this "brownout warning".
5. On the 8/10-channel DSM2 compatible and 10-channel DSMX compatible receivers a **rapidly flashing Green LED** at power up indicates 11mS frame rate mode.
6. On receivers equipped with a failsafe button, a **solid green LED** indicates that user-defined (preset) failsafe has been set. No green LED on these receivers indicates that failsafe is in the default mode, in which loss of signal triggers removal of all pulses from the output. This is explained in the section on failsafe, starting on page 11.

7. The 7ch Stabilized receiver has both **red and green LEDs** that are used to indicate binding and stabilization status as well as receiver version. See the separate instructions (available on the Lemon website or in the RCGroups Lemon Instructions thread) for information on setting up the stabilizer.
8. The 7ch Telemetry enabled PPM receiver has **red, green and blue LEDs** that are used to indicate binding, stabilization and PPM status. See the separate instructions (available on the Lemon website or in the RCGroups Lemon Instructions thread) for information on setting up this receiver.

4. Antennas and Satellites

All Lemon receivers are “full range”, including the “Light” series. In practice Lemon receivers match, or better, the range of comparable Spektrum DSM2/DSMX and other DSM2/DSMX-compatible receivers under the same conditions. However the range of any receiver is affected by the number of antennas (aerials) and their orientation, as well as by the installation in the model, making comparisons difficult.

Some Lemon receivers and satellites have one short active antenna wire, while others also have a second identical “reflector” wire. Some come with longer twin diversity antennas or have them as an option. For the strongest and most reliable reception there are a number of good practices to follow.

For receivers and satellites with short wire antennas:

1. The wire(s) should stick reasonably straight out from the receiver/satellite; where there are two, they should be in an approximately straight line. Antennas that are bent along the receiver/satellite board may have range reduced by 10-15%.
2. If a satellite is connected, it should be located as far as possible from the main receiver, not right next to it.
3. If a satellite is connected, most reliable reception is obtained when the satellite antenna and main receiver antenna are at right angles.

The larger non-diversity receivers (e.g., 7, 8- and 10-channel) do not have a second short antenna wire, as the circuit board serves the reflector function.

A small receiver with only a single antenna wire (including satellite-enabled receivers when operated without a satellite) will generally have less range by about 10-15% than an equivalent twin short antenna wire version. This is still ample range for normal flying.

For receivers and satellites with diversity antennas:

Receivers and satellites with diversity have two antennas made of coaxial cable with the last 32mm of outer insulation and conductive sheath removed to create a white or silver active portion (the antenna proper).

The antenna cables are connected to an electronic switch that selects the one currently with the stronger available signal. The receiver will switch antennas very quickly if the signal from the one it is using starts to drop in strength below the signal from the other antenna. The switching occurs within 300mS and no signal is lost during the switching period. This antenna-switching strategy is commonly called “diversity” in the RC world.

Some receivers also have a connector to allow the use of a satellite for additional signal robustness through another form of diversity. The satellite may be either a short antenna type or one with diversity antennas, but the protocols of receiver and satellite (DSM2 or DSMX) must match.

A satellite does not significantly increase the maximum possible range. Rather, as a separate stand-alone receiver it increases the probability that a reliable signal will be obtained at all times no matter the orientation of the model. The main receiver selects the stronger of its own best signal or that of the satellite. Note that if both the receiver and the satellite have diversity antennas this gives up to four separate signal sources for the receiver/satellite combination.

The antennas we use for radio control radiate (and receive) in all directions, but the signal is much weaker off the ends of the antenna (the active portion of the cable) than "broadside" to it. Think of an ancient naval battle where the ships had very little firepower fore and aft because most of their cannon were pointed out the sides.

To achieve the most reliable possible link to the model, therefore, what we want to avoid are situations in which the transmitter and receiver antennas are end-on to each other.

For the transmitter, the advice to the pilot is simple: don't point the antenna at the model.² For the receiver, things are more complicated because the model is constantly changing its orientation relative to the transmitter. A single receiver antenna will inevitably be pointed at the transmitter some of the time and thus in a relatively weak orientation for reception.

This is where diversity comes in. If the receiver has two active antennas positioned at right angles to each other, they can never both be pointed at the transmitter simultaneously. The receiver just has to select the antenna that is giving the better signal right now. That's what diversity switching does.

Diversity improves the reliability of the RF link in other ways. If the two receiver antennas are well separated, at least one should have a clear view of the transmitter, minimizing the risk of signal blanking by conductive materials on board the model. As well, with antennas at right angles, one of them should be somewhere near parallel to the transmitter antenna, thus roughly aligning polarization for a stronger signal.

Conductive materials such as foil coverings, batteries, metal components and carbon fiber can absorb and shield the incoming radio signal. Radio systems on 2.4GHz have a very short wave length and are susceptible to this. Receiver antennas need to be placed so that this effect is minimized.

In summary

What all this means for the installation of a receiver is simple.

If the receiver has dual diversity antennas, make sure the active tip portions are separated as far as practical from each other and from conductive stuff like

² Some Spektrum transmitters overcome this issue by incorporating dual diversity antennas oriented at right angles. The DX9 and 2016 version of the DX6 are examples.

battery, wiring and carbon fiber.³ Align these portions so they are at right angles to each other and reasonably straight. The coax cable portion of the antennas can be curved to achieve this but must not be sharply bent.

If a satellite is connected, it should be well away from the main receiver, not right next to it. Align it so the satellite antenna(s) and at least one main receiver antenna are roughly at right angles.

Take all this seriously but don't get paranoid. The installation doesn't have to be perfect to support an adequately strong RF link. Our modern receivers do a remarkable job of picking up the signal, even with just a simple single antenna. Diversity is not essential in most cases but can be thought of as extra security for when the going gets tough.

And, as always, **range testing is essential**. It should be done very thoroughly before the first flight of a new installation, with reception tested from all directions by walking around the model. If control becomes erratic from any direction at 25m range it's time to review and improve the installation. Once the setup is proven, a quick range check at 30 paces before the first flight of the day is all that's needed to check that things are working as they should.

5. Connections and Switches on the Various Lemon Receivers

The available range of Lemon receivers continues to evolve, with emphasis on DSMX compatibility, but the following information should be helpful even as the mix changes. Check the Lemon RX website for currently available units.

Lemon receivers have connections, plug orientation and switch function identified on the PC board or case. The positive pins for all channels (and the bind slot) are connected together, as are all the ground pins; power can be applied to any set of pins and if necessary a Y-cable can be used.

6 channel DSM2-compatible

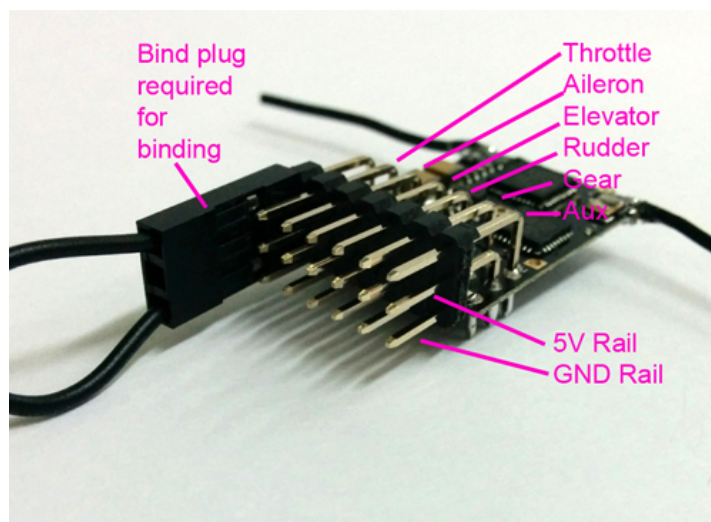

End pin and straight pin versions are similar.

³ Helicopters, multicopters and gliders that use lots of metal or carbon fiber construction require particular care in locating receivers and satellites to ensure that at least one antenna receives a clear signal regardless of orientation.

6 channel DSM2-compatible Ultra-Light

With JST-ZH 1.5mm pitch connectors. These connectors are the same as Spektrum AR6300 Nanolite receiver style.

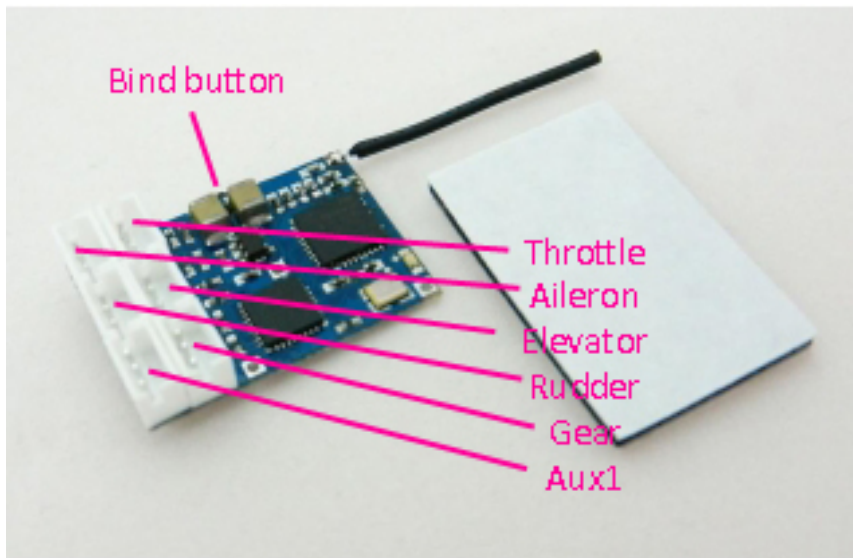

6 channel DSM2-compatible Micro Light

With JST-SH 1.0mm pitch connectors. These connectors are the same as Spektrum AR6400 Brick style for linear servos.

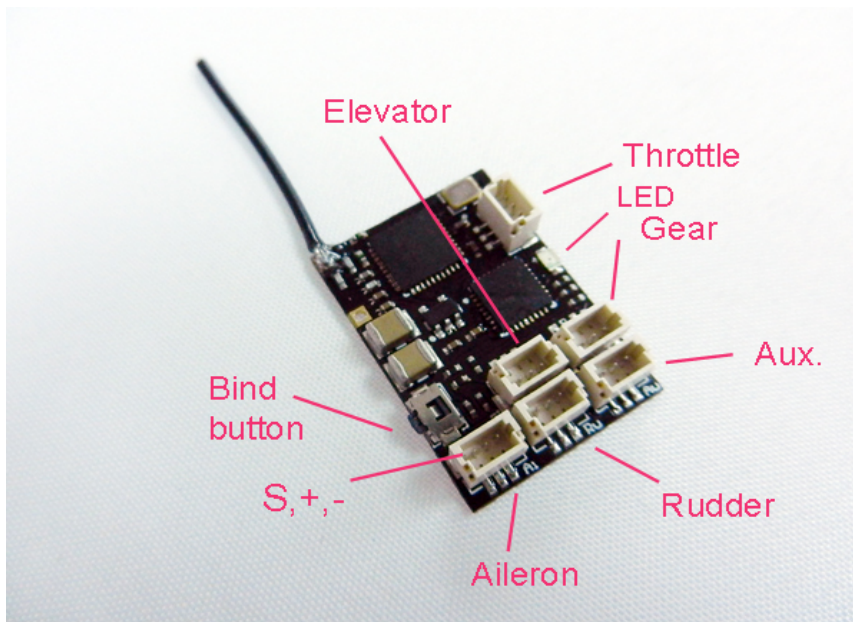

6 channel DSMX-compatible

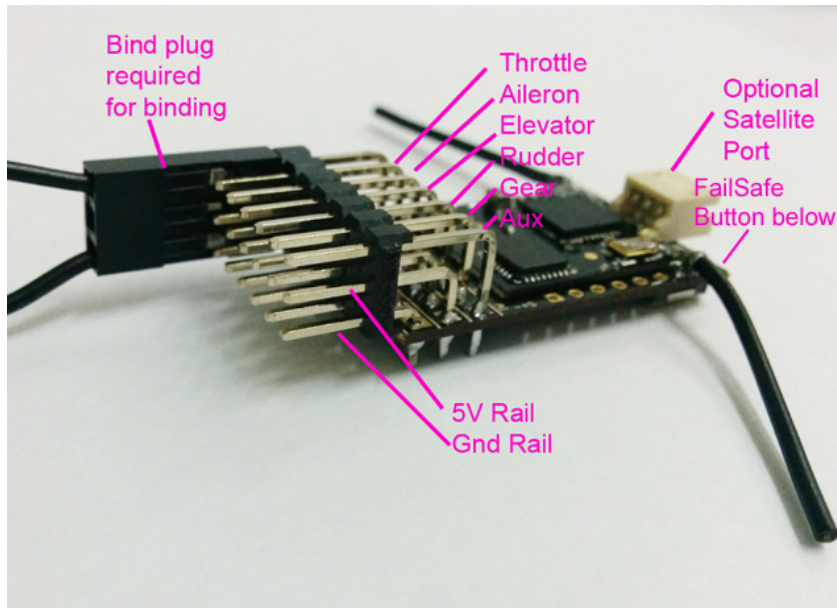

Only use a DSMX-compatible satellite with this receiver. It is also available in a diversity antenna version.

7 channel DSMX-compatible stabilizer

See separate instructions for details of how to set up the 7-channel stabilizer.



Only use a DSMX-compatible satellite with this receiver.

8 and 10 channel receivers

These receivers have been made in DSM2-compatible and DSMX-compatible versions. Use only the matching type of satellite.

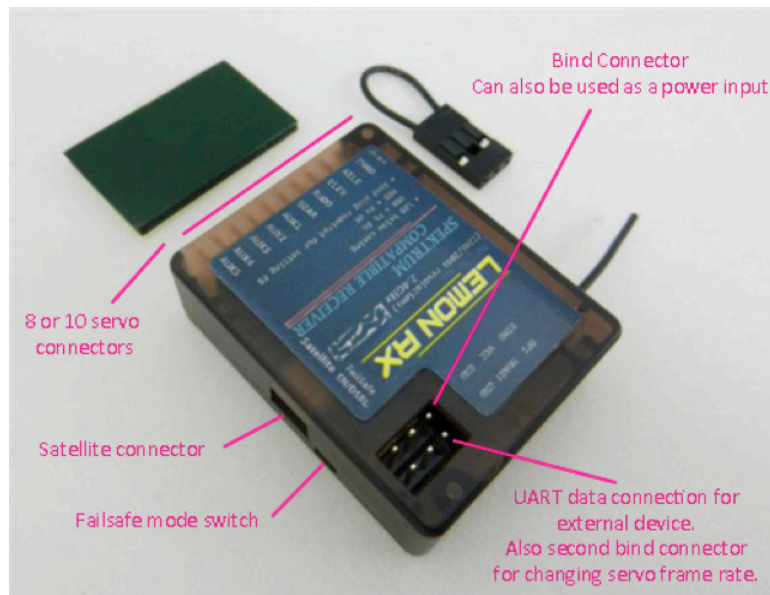

On these receivers a connector next to the bind connector is labeled “UART”. This is a serial connection that can provide data to other external devices such a controller or on-screen display. It is not used where the receiver stands alone.

To enable an 11mS refresh rate for high-speed digital servos, a bind plug is inserted in this connector during binding (see below).

Using 11mS Frame Rate

Both DSM2-compatible and DSMX-compatible versions of the 8-channel and 10-channel receivers can be set to function in 11mS mode. This should only be done when all servos are digital and capable of an 11mS refresh rate.

1. Insert bind plugs into both the Bind and UART connectors on the receiver.
2. Provide power to the unit. The red LED should flash rapidly.
3. Enable bind mode in transmitter (ensuring a distance separation of at least 3-6 feet/1-2 meters from receiver).
4. When the receiver binds and the LED is solid, power down and remove both bind plugs.
5. Every time from now on when the receiver is powered, a quickly flashing green LED indicates 11ms frame rate is enabled.
6. To cancel 11mS mode, rebind normally without the UART bind plug.

8 channel DSMX-compatible PPM receiver

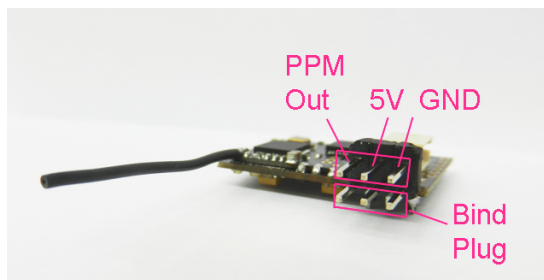
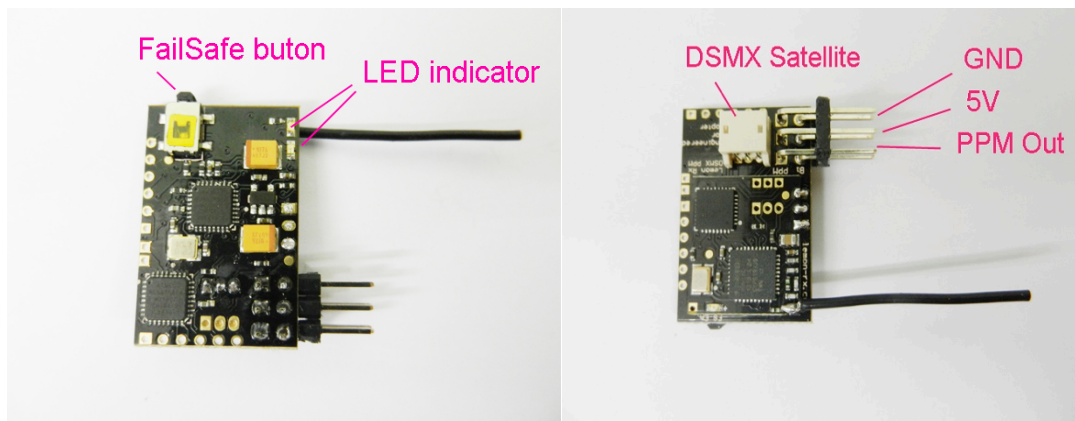

This receiver does not allow for connection of servos or a speed control. It is designed to provide a PPM (also called cPPM) stream suitable for use by a flight controller (or in a wireless trainer system or flight simulator).

Using the PPM stream with a Flight Controller

This receiver, and its DSM2-compatible predecessor, outputs channel pulses in the sequence sent by the transmitter, normally TAER. It cannot correct for incompatibilities such as that between a transmitter (such as the Spektrum DX8), which uses the standard Spektrum TAER channel order, and a flight controller such as NAZA that requires the so-called Futaba sequence of AETR. For transmitters such as the Spektrum DX9, FrSky Taranis or Turnigy 9XR, in which the channel assignments can be changed, this is not an issue.

The ability to allow the user to switch between TAER and AETR receiver output (given transmitter channel order of TAER) is now available on the 7channel Telemetry enabled DSMX-compatible diversity PPM receiver. See separate instructions for details of how to set up that receiver.

Satellite Receivers

The Lemon DSMX and DSM2-compatible satellites look similar but the plastic housing is marked with the letters "DSMX" or "DSM2" (obliterated in the photo). The correct satellite should be used with a receiver.



Note that the satellite must be attached to the receiver for binding. Both will show a solid red light when bound.

6. Failsafe⁴

The primary purpose of failsafe is to minimize the risk of injury and damage should the receiver lose signal while the model is powered up, whether flying or on the ground. The key safety requirement is that the motor be shut down on loss of signal.

Three types of failsafe are used by the various Lemon receivers:

1. Throttle-only Pre-set

On loss of signal, the throttle goes to a preset position determined by the position of the throttle stick during binding. Other channels receive no pulses and thus servos stay in their current positions. This is similar to the Spektrum "Smart Failsafe" approach.

To set the correct throttle failsafe the user must place the throttle stick in full low position when binding. *This is very important!*

This type of failsafe is used only by the Light series of 6-channel DSM2-compatible receivers.

2. No Pulse

Modern speed controls (ESCs) go automatically to OFF if no control pulses are available. This important safety feature can be used to achieve failsafe behavior if on loss of signal the receiver cuts off pulses to the ESC and other channels. This results in the motor shutting down and the servos not moving.

An advantage of this approach is that it does not rely on the operator to ensure that the throttle stick is at low position when binding. However, it is not suitable for use with a model powered by an internal combustion engine (glow or gasoline), or with an ESC that lacks auto off.

This type of failsafe is used by the Lemon 7-channel stabilizer.

No Pulse Failsafe is the **default** for the 6-channel DSMX-compatible, 7-channel Telemetry enabled DSMX-compatible PPM receiver, 8 and 10 channel DSM2-compatible and DSMX-compatible receivers, and 8-channel PPM receivers (both the current DSMX-compatible version and the earlier DSM2-compatible unit).

3. User-Defined Failsafe

This type of failsafe allows the operator, after binding the receiver, to set the desired failsafe positions of all channels. This allows for such special failsafe requirements as having a glider go into a spiral with spoilers deployed in order to prevent a flyaway. Likewise, multicopters may have a failsafe command to return home using GPS.

User-Defined Failsafe, also known as Pre-set Failsafe, is a user set **option** on the 6 channel DSMX compatible, 7-channel Telemetry enabled DSMX compatible PPM receiver, and 8 and 10 channel receivers, including the PPM units.

As explained above, the **default** for these receivers is No Pulse Failsafe.

⁴ This section has been revised to correct some information in the first version of the instructions.

Setting User-Defined Failsafe. Where user-defined failsafe is available, the receiver can be set to use it as follows:

1. Power up the transmitter and receiver (which should already be bound). Do NOT have the transmitter in bind mode.
2. Apply the bind plug to the receiver bind pins (with power on).
3. Set the transmitter controls to the desired failsafe positions.
4. Press in the failsafe switch on the receiver briefly.
5. The Green LED on the receiver will turn on to indicate that failsafe positions have been stored.

Henceforth, whenever the receiver is powered up, the green LED will indicate “user-defined failsafe”. If signal is lost, the receiver will output the pre-set positions after approximately 3 seconds and maintain them until a valid signal is again received.

Test the failsafe settings by turning off the transmitter, after taking all necessary precautions, such as removing propellers or restraining the model.

To return to the default no-pulse failsafe with these receivers, simply rebind the receiver normally.

NOTICE

This manual is provided to help you understand and use the Lemon RX receivers. The authors are not associated with Lemon RX and this is not a Lemon RX publication.

You can freely quote from, redistribute and/or modify this manual; in doing so please acknowledge the source and any changes.

The manual is distributed in the hope that it will be useful, but WITHOUT ANY WARRANTY; without even the implied warranty of MERCHANTABILITY or FITNESS FOR A PARTICULAR PURPOSE. See the GNU General Public License for more details. In using this manual, you agree that you accept all responsibility.

For more information on the Lemon RX receivers, see

<http://www.rcgroups.com/forums/showthread.php?t=1773138>

<http://www.lemon-rx.com/shop/index.php?route=common/home>

Written by RCGroups users jj604 and Daedalus66

March 2015, February 2016

Lemon RX manual_V2.docx